



## ETSP-16 LCD VOIP POE WEATHERPROOF TELEPHONE

This Weatherproof phone is manufactured & designed for minning, railways, power stations, metros, tunnels, motorways & airports. Housed in robust aluminium die case with a spring loaded door, it will offer protection against the outdoor environment, it is also vandal & rot resistant.

The unit will meet all the latest Australian, standards for EMC and US FCC, telephony, waterproofing IP67, and lightning protection while offering the level of performance and reliability demanded in such an environment.

- Standard Analogue and VoIP-SIP options available
- DTMF(Dual Tone Multi Frequency)
- Matching with most PABX,PBX and PAX systems or IP PABX.
- Phone line powered, or AC powered for VOIP or POE



Sales and Service:



**Emergency Telephones**

PO Box 606 Rockdale NSW 2216

Telephone: 02-9599-9555

Fax: 02-9599-9225

Email: [sales@emergencytelephones.com.au](mailto:sales@emergencytelephones.com.au)

[service@emergencytelephones.com.au](mailto:service@emergencytelephones.com.au)



# Emergency Telephones

100% Australian Owned

## 1.1 Main Product features

1. Robust aluminium alloy die-cast body,
2. Full keypad with memory, 10 button programmable speed-dial telephone, Illuminated button optional.
3. Keypad with shining painting for self illumination in dark area.
4. Weather resistant to **IP66** standard, service temperature range from:-10°C to +75°C
5. Magnetic reed hook-switch
6. PoE-Power over Ethernet, No external power or battery back up required.
7. Lightening protection to ITU-T recommendation K.21
8. Handset: made of special engineering plastic, high anti-knock resistance, weatherproof, armoured cable
9. Hearing Aid compatible receiver, noise canceling microphone.
12. Vandal resistant and tamper-resistant hardware,
13. Easy installation/ replacement
14. Last number redial
15. Adjustable ringer and volume control inside

## 1.2 Telephone layout

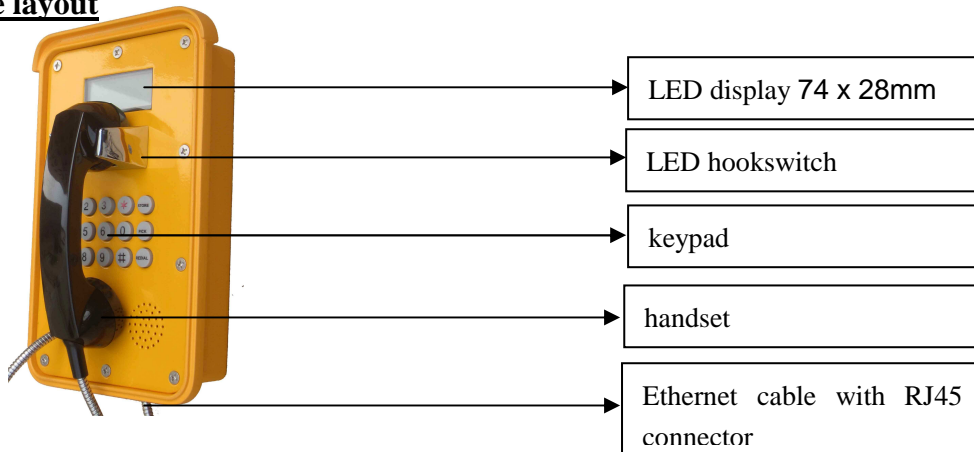

## 1.3 Construction

### 1.3.1 Connection cable

Stainless steel connection cable to exchange. Well treated keep waterproof.

### 1.3.2 Mounting bracket

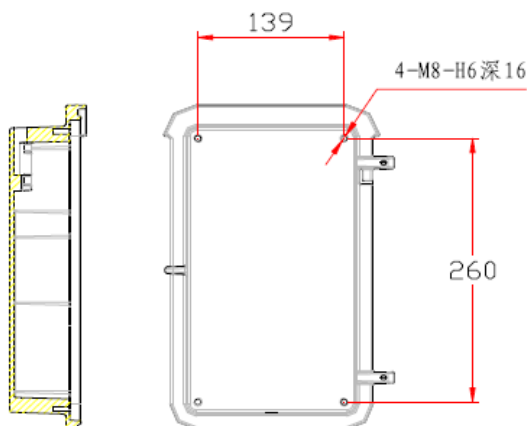



# Emergency Telephones

100% Australian Owned

## 1.3.3 Handset

- Kirk electro dynamic transducer for both handset transmitter and receiver
- Spring cable or armoured cable to attach the handset to the telephone main unit
- Stainless steel cable to connect exchange.
- Inductive coupler fitted for hearing aid compatibility.
- Handset integrity wiring to enable exchange to check if the phone is still operational.

## 1.4 ELECTRONIC

### 1.4.1 Main PCB

- ◆ Well treated PCB used inside the phone.
- ◆ Robust screw terminals used for the connection of ringer, handset, line in, hookswitch.
- ◆ All connectors be greased in production.

## VOIC OVER IP- SIP

Item		this VoIP Phone
Adapter(Input/Output)		Input:100-240VAC 50~60Hz      Output:5V/1A Or POE optional
Port	WAN	10/100Base- T    RJ-45 for LAN, Auto MDIX
	LAN	10/100Base- T    RJ-45 for PC, Auto MDIX
Power Consumption		Idle:1.5W/Active:1.8W
LCD size		74 x 28mm
Operation Temperature		0~40°C
Relative Humidity		10~65%
Main Chipset		Broadcom
SDRAM		8Mbits
Flash		2Mbits
Size (W x H x D)		11.6x8x3 in.(295x205x75mm)
Weight		2.07lb.(0.94kg)

### 5.1.2. Voice Features

- Support 2 lines SIP, SIP 2.0 (RFC3261)
- Codec: G.711A/u, G.7231 high/low, G.729, G.722, G.726
- Echo cancellation: Support G.168 and hand-free can support 96ms
- Support VAD, CNG
- NAT transverse: support STUN
- Supports full duplex.
- SIP support SIP domain, SIP authentication (none, basic, MD5), DNS name of server, peer to peer



## Emergency Telephones

100% Australian Owned

- SIP support 2 servers, user can through each server to calling in and out
- DTMF:SIP info, DTMF Relay, RFC2833
- SIP application: contain SIP call forward/transfer/holding/waiting/3 way conference/Paging and intercom/ click to dial/pickup/ joincall/redial/unredial.
- Call control features: Flexible dial map, support hotline, empty calling no. reject server, black list for reject, authenticated call, no disturb, caller ID and so on.
- Could dial use private server automatically when public server unregistered while private server is registered successfully
- Support phonebook 500 records, incoming calls / outgoing calls / missing calls. Each supports 100 records
- Support MWI
- support conference call in server
- Phonebook supports VCard standard
- Support 12/24 time format.
- Support daylight saving time
- Support path, gruu
- Support SIP Privacy.

### 5.1.3. Network Features

- WAN/LAN: support Bridge mode.
- Support PPPoE for xDSL
- support VLAN
- Support Stun penetration
- Support DHCP get IP on WAN port
- Qos supports Diffserv.
- support network tools: contain ping, trace route, telnet client

### 5.1.4. Maintenance and Management

- The phone supports post mode, can update firmware by post mode.
- Supports different levels of administration.
- Support Boot Monitor
- Can upgrade firmware through boot monitor
- access with different authority
- support auto provisioning
- Can config through Web, Keypad, Telnet
- Can upgrade firmware and configuration file through HTTP, FTP, TFTP
- Support syslog

## 1.5 Certification: N30788



**EMC: EN50121 (Railway application- Electromagnetic Compatibility)**

**EN55022: emissions**

**EN55024: immunity**

**Ingress Protection: GB4208-93 IP67**

**FCC**